

the dryerbox™ THE RECESSED DRYER VENT BOX



Use the 350 Dryerbox if venting straight up in a 2x4 wall. Use the 425 box in a 2x6 wall or a 2x4 wall that requires any elbows - and single fit that 2x4 wall

All dryers vent at the very bottom. Install The Dryerbox resting on bottom plate.

US Patent 5,476,183 Others Pending

The Dryerbox is a simple innovative space saving metal receptacle that installs in the wall behind the clothes dryer in the laundry room. The box will house and collect the flex transition hose allowing the clothes dryer to be installed right against the wall. Eliminating the bends in the flex exhaust hose provides for better, less restrictive airflow, which in turn minimizes lint buildup, saves energy costs and reduces fire hazard. Gas line knockouts located on the tops of the boxes.

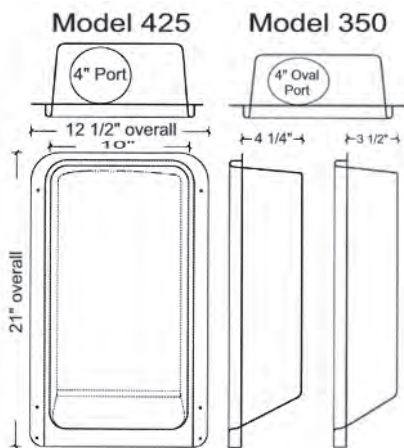

Locke#

L3525	DB-350	4 7/8" Deep, Oval Hole top exhaust, Dryer Box
L3526	DB-425	5 1/8" Deep, Round Hole top exhaust, Dryer Box
L3527	DB-4D	5 1/8" Deep, 4 7/8" Round Hole, Bottom Port Downflow Dryer Box. Overall dimensions: 19"h 16 3/4"w 5 1/8"d.
L3529	DB-3D	4 7/8" Deep, 4 7/8"x3 1/8" Oval Hole, Bottom Port Downflow Dryer Box. Overall dimensions: 19"h 16 3/4"w 4 7/8"d.



DRYER EXHAUST FITTING



The Dryer-ELL™ is engineered to provide a net gain of approximately 4.8 feet in allowable duct length. Based on ASHRAE methodology for calculating friction loss, it delivers a significant savings by eliminating the standard 5 foot reduction.

FEATURES:

- Gain 4.8 feet of duct run
- Approved 2006 IRC, Section M1502.6
- Increases dryer efficiency
- Replaces restrictive 3" radius elbow
- Alternative to a booster fan

Locke#

L3531	LT90	Dryer Exhaust Fitting
-------	------	-----------------------



4" DRAFT BLOCKER

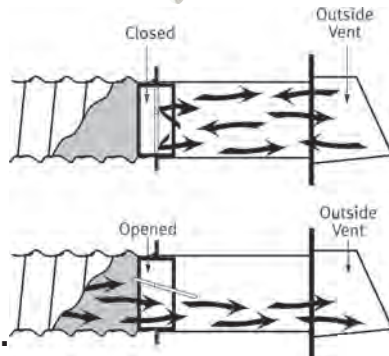

- 4" diameter opening
- A quick easy installation
- Helps stop cold air from entering
- Plastic construction with balanced damper fully assembled

Locke#

L3538	4"	plastic draft blocker
-------	----	-----------------------



FLEXIBLE VENT HOSE FOIL DUCT Not for Dryers



UL® 181, Class 1 air connector label.

Locke#

L3499	3" x 50'	Foil duct
L3500	4" x 5'	Foil duct
L3508	4" x 50'	Foil duct
L3540	5" x 25'	Foil duct
L3541	6" x 25'	Foil duct



FLEXIBLE ALUMINUM DUCT



Locke#

L0505	V320	3"x8' flex. alum. duct
L0506	V320	4"x8' flex. alum. duct
L0507	V320	5"x8' flex. alum. duct
L3511	V320	6"x8' flex. alum. duct
L3512	V320	7"x8' flex. alum. duct
L3528	V320	8"x8' flex. alum. duct



4" CLOSE ALUMINUM ELBOW

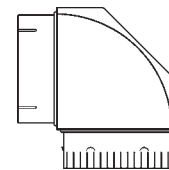

Turns 90° within 4.5". 1 male & 1 female rotating snap-lock fitting. Best choice for 90° turns, especially on the dryer.

Locke#

L3514	110108	4" Close Elbow
-------	--------	----------------

HVAC

Clothes Dryer Venting, hoods & boosters



DRYER VENT KIT



Each kit contains Supurr-Flex Aluminum Flex Duct, aluminum pipe, white hood, collar, & clamps.

Locke#

L3501 8' vent kit



LOUVERED VENT HOODS



Locke# Vent hood only.

L3502 4" White Hood

L3518 4" Brown Hood

L3504 6" White Hood



ROOF DRYER VENT HOOD

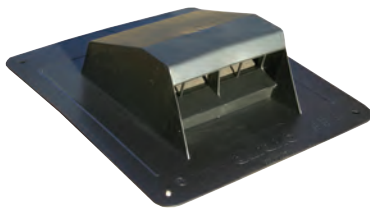

- Low profile design
- Has a easy-cut tailpiece to change the 4" diameter opening to a 5" diameter opening
- Durable weather resistant

Locke#

L0321 Vent with flapper, no grid, collar



DRYER VENT HOOD

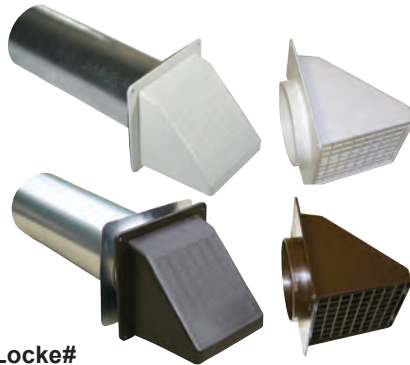

Locke#

L3510 4" white hood assembly with bird guard: hood, pipe & collar

L3517 4" brown hood assembly with bird guard: hood, pipe & collar

L3515 4" white hood only

L3516 4" brown hood only



ALUMINUM VENT HOODS

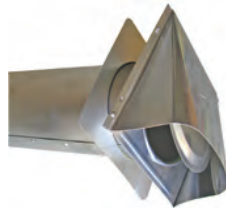

Includes hood, aluminum pipe & collar

Locke#

L3505 3" Aluminum Vent Hood

L0488 4" Dryer Vent Hood

L0491 4" Metal Dryer Hose Clamps

deflect-o® UNDEREVE VENT KIT For Dryer and Bathroom Exhaust Venting (Soffit)

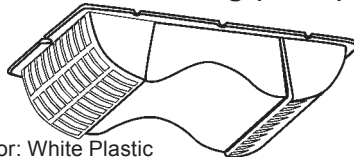

Color: White Plastic

- Quick, easy installation
- Installs over the exhaust hole, under the soffit to exhaust air from dryers/bathroom fans
- Helps prevent cold air from entering home, birds and rodents from nesting in vent

Locke#

L3547 EVE/6 White under eve vent



DRYER EXHAUST BOOSTER FAN With Air Pressure Switch or Current Sensing Switch



Includes:

- PV100x Exhaust Fan (142 CFM)
- Air Pressure Switch with electronic cycle timing or Current sensing switch
- 1 Plastic Round Grill (BOR-100)
- 4 Nylon Tie Wraps (TW-4)
- Mounting Bracket

Locke# Model Description

L3600 PV-100X Pressure Sensor Kit

L3601 PV-100X Current Sensor Kit

deflect-o® DRYER EXHAUST BOOSTER FAN

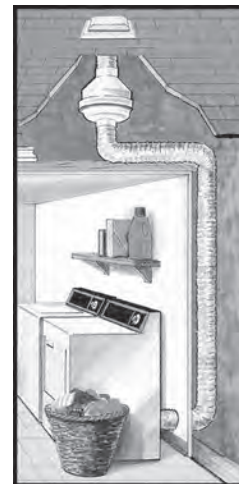
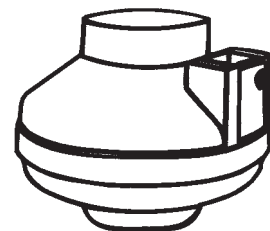

Specially Built to force the wet, hot, lint laden air through your duct and outside. Use **L1060** Air switch to install.

Locke#

L3522 TF4 4" 120 cfm Fan

L1060 Dual purpose air switch

bAt hr oom exhAust Kits & V inyl hose



SINGLE BATHROOM EXHAUST FAN KIT

For most standard bath installations



Includes:

- 1 TD100 Exhaust Fan
- 1 Plastic Round Grill (BOR-100)
- 1 Exterior Fixed Grill (GR-100)
- 4 in. Flexible Ducting (GSA) 13 ft.
- 1 Roll Adhesive Tape (BA)
- Integral Mounting Bracket

Locke# Model

L3605 TD100 Single Exhaust Fan Kit



DUAL BATHROOM EXHAUST FAN KIT

For most standard bath installations



Includes:

- 1 TD150 Exhaust Fan
- 2 Plastic Round Grills (BOR-150)
- 1 Y-fitting (SY-6)
- 7 Nylon Tie Wraps (TW-6)
- Integral Mounting Bracket

Locke# Model

L3606 TD150 Dual Exhaust Fan Kit



8' FLEXIBLE VINYL DUCTS

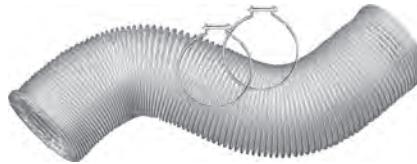

Not Recommended For Dryer Venting

Locke#

L0490 8ft. White Vinyl Vent Hose, 4" diameter with clamps

L0491 4" Metal Dryer Hose Clamps



50' FLEXIBLE VINYL DUCTS



Not Recommended For Dryer Venting

Locke#

L3506 3" x 50' White Flexible Vinyl Hose

L0524 4" x 50' White Flexible Vinyl Hose

L0491 4" Metal Dryer Hose Clamps



EAVE VENT WITH DUCT

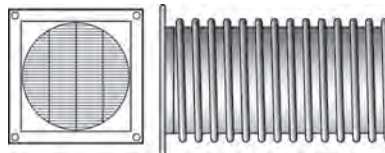

Installs flush with eave. Good for bathroom venting or Fresh Air Intakes.

• **Not for clothes dryer venting.**

Locke#

L3536 110274 3" Vent with 3' duct

L3520 110275 4" Vent with 3' duct

L3533 110556 3" Vent only

L3521 110555 4" Vent only



VINYL DUCT VENT KIT



Hood

- Calcium filled Polypropylene
- Melting point: 325° F approximately
- UV Inhibitor added

Pipe

- Aluminum

Collar

- Styrene

Clamps

- 4" diameter, polypropylene plastic

Duct

- 4"x5' flexible, vinyl duct

Operating Temperature Range

- 190°F approximately

• **Not Recommended For Dryer Venting**

- Flexible, easy to install vinyl duct
- Quick, easy installation kit
- Duct clamps included
- Durable, weather resistant hood
- Wide mouth hood damper operates quietly for maximum exhaust air flow and seals when not in operation to help prevent back drafts
- Removable bird guard helps prevent birds and rodents from entering home through your dryer vent

Locke# COMPLETE KIT

L0489 Complete Dryer Vent Kit

L0491 4" Metal Dryer Hose Clamps

HVAC



FURNACE FRESH AIR INTAKE VENTS

With molded plastic screen



Locke#

L3503 6" White Furnace Fresh Air Intake Vent

deflect-o[®] GALVANIZED RECTANGULAR DUCT WALL STOCK

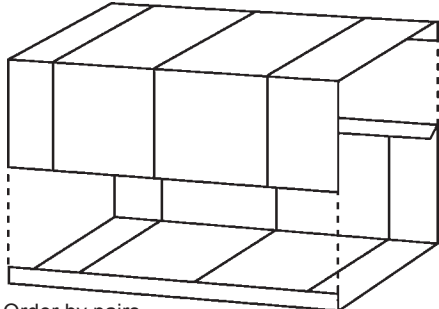

Order by pairs
6 pairs to master carton
2 Pairs = 1 Section

Locke#

L3519 DGD32 3 1/4" x 10" x 2'

Cody Company, Inc.

RANGE HOOD VENT TRANSITION

No. 201



Locke#

L3509 3 1/4 x 10" to 7" Round Transition



L.L. Building Products Inc.

55 SERIES ROOF LOUVERS



Square hood design for effective weather protection & maximum air movement. Recommended for duct outlet in kitchen & bath exhaust fan installation. Can be used on any style/ pitch roof, not exceeding 6/12.

Locke#

L0314 R-50A Aluminum



L.L. Building Products Inc.

FLUE/HOT STACK CAPS

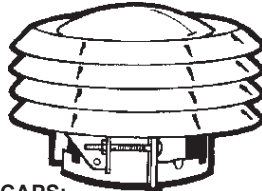

VERSA-CAPS:

Non-clogging positive draft design, recommended for flue or hot stack install. Clamp fitting adjustable for all standard sizes.

Locke#	Pipe O.D.	Pipe Sizes	Overall Ht/Diam
L0316	2 7/8-5	3&4	4 1/2; 6 5/8
L0317	4 7/8-7	5&6	4 3/4; 9 1/2
L0348	6 7/8-9	7&8	11 5/8

Locke#

L0316 3050G Flue/Hot Stack Cap

L0317 3070G Flue/Hot Stack Cap

L0348 7090 Flue/Hot Stack Cap



MANUFACTURED BY



L.L. Building Products Inc.

POWER ATTIC VENTILATOR

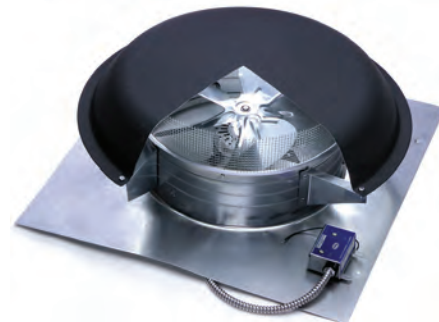

Maintenance-free construction. Cushioned motor mounts for quiet operation. Insect screening. Adjustable automatic thermostat. Corrosion resistant dome. Thermal overload protected motor. 1/10 HP, 240 watts, 115 volts, 3.4 amps.

Locke#	Vendor#	CFM	Attic Sq. Ft.	Warranty
L0318	PR1D	1000	1600	5 yr.
L9994	X11385D	Fan Blade for L0318		
L0319	PR2D	1250	2400	5 yr.
L9995	V930501	Fan Blade for L0319		
L9996	H1	Humidistat for power vents		
L9997	PVM105	Motor for L0318 & L0319		
L9999	PT6	8 amp, replacement thermostat for L0318 & L0319 , 60 Hz		

WHY PAY MORE?!

COMPARE OUR PRICES AND SAVE!

FORANE
REFRIGERANTS

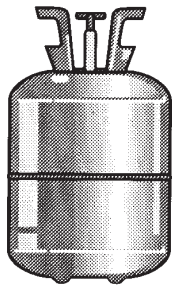

#22 REFRIGERANT

For reciprocating centrifugal rotary compressor units. Operates with relatively high system pressures, but offers a low compression ratio. Universally used in packaged air conditioners & finds wide commercial & industrial application.

Locke#

L0848 R22 30 lb. Cylinder HCFC

410A REFRIGERANT

Locke#

L1384 410A 25 lb. (lavender) Cylinder, HCFC-22 replacement of newer high efficiency condensers.

409A REFRIGERANT

Locke#

L1386 409A-FX56 30 lb. cylinder. HCFC Product. Alternative f/ retrofit of R12

134A REFRIGERANT

Locke#

L1387 134a 30 lb. Cylinder HFC Product. Alternative for R12 with oil change. (Lt. Blue)

404A REFRIGERANT

Locke#

L1388 404A 24 lb. Cyl. HFC Product. Can be used to retrofit many R502 applications. (Orange)

#R408A REFRIGERANT

A retrofit solution for medium & low temperature refrigeration systems which are currently using R502.

Locke#

L0849 24 lb. Refrigerant #R408A

ICOR International
producers and distributors of environmentally safe refrigerants

ONE SHOT™



Replaces R-502, R-404A, R-402A R-402B R-408A, R-507A and R-22 (Low Temperature Applications)

Available in 24 lb. cylinder

- EPA Snap Listed
- Compatible with all standard refrigerant oils
- Lower conversion costs
- Backed by warranty
- Manufactured in accordance with ARI 700-2004
- Higher capacity & cop than R-404A & R507 A
- Lower compression ratio than R-404A and R-507A 20% lower global warming potential
- Zero ozone depletion potential
- Nontoxic and Nonflammable
- Suitable for new and existing equipment

Locke#

L1302 OS- 24 24 lb. Cylinder

WE DO MORE THAN JUST MEET OUR COMPETITION... WE BEAT THEM!!

ICOR International
producers and distributors of environmentally safe refrigerants

HOT SHOT DIRECT REPLACEMENT REFRIGERANT

The most versatile alternative refrigerant on the market today!



- HOT SHOT is a direct replacement for R-12, R-134a & R-500.
- UL classified & has a nontoxic, nonflammable classification from ASHRAE.
- HOT SHOT is EPA accepted for use in both mobile & stationary equipment. All mobile A/C alternative refrigerants are subject to EPA use conditions.
- HOT SHOT is miscible with all refrigeration oils in use.
- HOT SHOT is 8% more efficient than R-12, 15-20% more than R-134a.
- HOT SHOT will reduce multiple refrigerant & regeation oil inventories.

Locke#

L1390 R414B 25 lb. Refrigerant

L1391 R414B 10 oz. Refrigerant

T0534 HSVT 10 oz. can valve tool

T0535 HSHA1R Valve to flare adapter

T0539 HSCTA Flare to R-134a fitting

MA-LINE
MORTI AND ASSOCIATES, INC.

REFRIGERANT LABELS

<input type="checkbox"/>	ALL CFC'S AND HCFC'S REMOVED
<input type="checkbox"/>	ALL OIL REMOVED
<input type="checkbox"/>	APPLIANCE DOOR/HINGE REMOVED
SAFE FOR DISPOSAL	
CERTIFIED TECHNICIAN _____	
COMPANY _____	
ADDRESS _____	
PHONE _____	

Locke#

M0345 MA-SDF1 5½" x 8½" Safe for Disposal Label

HVAC

**Hydro
Balance**

Z-LUBES

*Synthetic Alkylbenzene
Refrigeration Lubricants*



Packaged by Hydro-Balance Corp. under strict quality controls in our ISO 9001 certified facility. They are manufactured by a leading producer of alkylbenzene lubricants. These lubricants meet or exceed the specifications of most equipment manufacturers including: Bristol, Carrier (Carlyle), Carrier Transicold, Copeland, York, FES, General Electric, Scroll Technologies, ThermoKing, Danfoss, Frick, Tecumseh.

Locke#	Vendor#	Description	SUS Visc.	Size
M1072	Z150-01	Alkylbenzene Refrigeration Oil Replaces Zerol 150, RF 150, AB 150, ROYCO 2032	150	1 gal.
M1073	Z300-01	Alkylbenzene Refrigeration Oil Replaces ZEROL 300, AB 300	300	1 gal.

Typical characteristics	Test	Z150	Z300
Viscosity, cSt @ 40°C	D445	32	68
Viscosity, SUS @ 100°F	D2161	150	300
Specific Gravity 60/60°F	D1298	0.87	0.87
Flash Point COC	D92	175°C	175°C

**Hydro
Balance**

SYNTHETIC ESTER LUBRICANTS

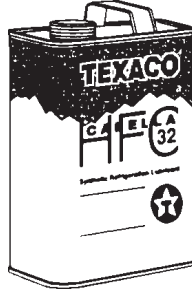

Marketed and packaged by Hydro-Balance Corp., are manufactured by a leading producer of synthetic refrigeration lubricants. Available in ISO Viscosity Grades: 32, 68, 100, and 220. These lubricants meet the specifications of many compressor and equipment manufacturers including: Carrier, Carlyle, York, Carrier Transicold, Bitzer, Bristol, Dunham-Bush, Climate Control, Danfoss, Hitachi, Mycom, Tecumseh, Blissfield

Locke#	Vendor#	Description	SUS Visc.	Size
M1074	P3201	Synthetic Ester Lubricants,	150	1 gal.

Typical characteristics	Test	32
Viscosity, cSt @ 40°C	D445	32

**MAKE MONEY
THE EASY
WAY.
BUY RIGHT
AND SAVE!!**

**BRAMEC®
CORPORATION**

PUMP-UP EQUIPMENT STAND



Features:

- Easy to install
- Top diameter 48"
- Elevate heat pumps & air handling units
- Polymeric mastic included with each unit
- Absorbs vibration & noise
- Over 20 years of proven service
- Made of corrosion-resistant plastic
- Allows better condensate drainage
- Helps prevent corrosion of metal base

Locke#

L0681	4005	3" Pump-up, 6x6" base
L3311	4008	6" Pump-up, 6x6" base

**BRAMEC®
CORPORATION**

SCREW-UP EQUIPMENT STAND



Features:

- Simple to install
- Elevate heat pumps & air handling units
- Polymeric mastic included with each unit
- Absorbs vibration & noise
- Made of corrosion-resistant plastic
- Allows better condensate drainage
- Helps prevent corrosion of metal base
- Easy leveling or adjustment of units during & after installation
- Reduce or eliminate call back time

Locke#

L3312	4007	6"-7¼" adj. screw-up
-------	------	----------------------

HVAC

A/C PADS



CLADLITE® LIGHTWEIGHT CONCRETE PADS

Concrete appearance & performance
at 1/5-1/8 the normal weight.

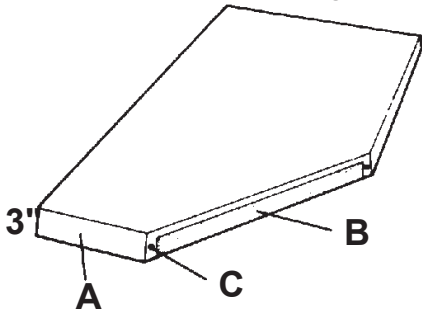

- Completely guaranteed with normal use
- Over 70 sizes
- Lightweight, easy to handle, strong, durable, attractive
- Breakage resistant
- Code approved

Construction Details:

- A.** The fiberglass reinforced cement composite used as the cladding for Cladlite pads is pound for pound stronger than ordinary concrete. This has characteristics than ordinary concrete, an important factor in areas that snow and ice. There is no need to paint Cladlite pads, as the cladding is $\frac{3}{8}$ " thick on the top surface and 1" thick around the sides for the best possible combination of strength, lightweight, and concrete appearance.
- B.** The core makes Cladlite pads vibration and sound absorbing, and addition to making them extremely lightweight. The polystyrene foam used in Cladlite pads is not harmed by water, soil conditions, fungus, bacteria or insects. The foam core is firmly bonded to the cement cladding and will last indefinitely with normal use.
- C.** Most sizes have steel reinforcing.

Locke#	Size	Weight
L0658	24" x 24"	34 lb.
L0693	24" x 30"	43 lb.
L0660	30" x 30"	51 lb.
L0661	30" x 40"	64 lb.
L0659	32" x 32"	55 lb.
L0662	36" x 36"	68 lb.
L0797	36" x 40"	86 lb.
L0663	36" x 48"	110 lb.
L0697	48" x 48"	140 lb.
L0695	50" x 70"	206 lb.



ULTRALIGHT-WEIGHT EQUIPMENT PADS

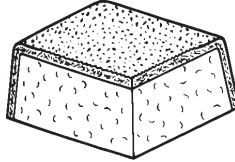

- Textured surface prevents unit slide and allows water drainage.
- Amazingly tough fiber-cement composite stops cracks and breaks with excellent flexing qualities.
- EPS core dampens vibration, conforms to uneven ground, and prevents mold and fungus.

Locke#	Size	Description
L0671	24" x 24" x 3"	Ultralight Pad
L0672	30" x 30" x 3"	Ultralight Pad
L0698	30" x 40" x 3"	Ultralight Pad
L0673	36" x 36" x 3"	Ultralight Pad
L0674	36" x 42" x 3"	Ultralight Pad
L0675	36" x 48" x 3"	Ultralight Pad
L0676	48" x 48" x 3"	Ultralight Pad
L0677	50" x 56" x 3"	Ultralight Pad

The Black Pad® AC PADS

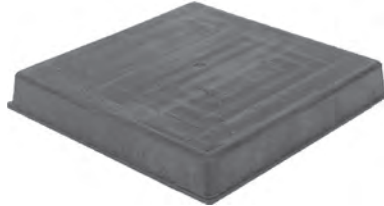

- Replaces Wooden or Concrete Pads.
- Strong. Durable. Lightweight!
- Easy to Install.
- Reduces Vibration/ Noise
- Easy to Handle and Breakage Free
- Economical - Made from 100% Recycled Materials.
- UV Stabilizing - Prevents Weathering
- Absorbs Radiation

Locke#	Size
L6671	24" x 24" x 3" Poly Vulc AC Pad
L6672	30" x 30" x 3" Poly Vulc AC Pad
L6673	36" x 36" x 3" Poly Vulc AC Pad
L6674	32" x 44" x 3" Poly Vulc AC Pad
L6675	36" x 48" x 3" Poly Vulc AC Pad

MADE IN
OKLAHOMA!



- 3/4" Top
- Self-Leveling
- Will Not Sink
- Drill and Tap
- Will Not Crack
- Will Not Fade

Perma Pad is easy to store, transport, and install. Perma Pad will not break, crack, or chip. Perma Pad is made with high quality materials, including a UV stabilizer to prevent sun-aging.

Locke# Size

L6681	24" x 24" x 3"	Pad
L6682	30" x 30" x 3"	Pad
L6683	36" x 36" x 3"	Pad

BRAMEC® CORPORATION SUPER-DUTY RUBBER PAD



Features:

- All rubber construction
- Reduces vibration & noise from air-conditioning & refrigeration equipment
- Compounded for excellent resistance to aging, compression & oil
- Easily cut into 2" x 2" squares

Locke#

L3404	19709	18" x 18" x 3/4" Iso-Pad
-------	-------	--------------------------

BRAMEC® CORPORATION ANTI-VIBRATION PADS

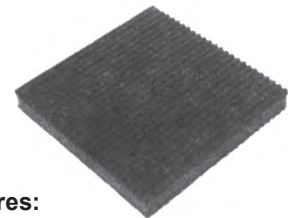

Features:

- Has a solid cross-ribbed design ($\frac{3}{8}$ " thick)
- Made from high quality materials
- Ribbed design with a cork center ($\frac{7}{8}$ ")
- Compounded for excellent resistance to aging, compression set & oil
- Recommended maximum loading capacity: 50 Lb. per square inch

Locke#

L0807	6132	2" x 2" x $\frac{7}{8}$ " Cork/ Rubber Anti-Vibration Pad
-------	------	--

HVAC

Little GIANT Pump Company
ELECTRONIC CONDENSATE PUMP



The EC-400 is a complete pumping system designed to remove condensation from wall mounted, ceiling and coil split-system air conditioning equipment when gravity drainage is not possible. Compact design allows installation in most split-systems. Components can be placed into the air handler or the pump can be placed up to 3' above the air handler in the ceiling void or inside trunking conduit. A three position symmetrical float sensing system assures reliable ON, OFF and OVERFLOW DETECTION functions.

- For intermittent operation, maximum 50% duty cycle
- Condensate produced in application must be no more than half the pump's flow rate for any given head
- Use with most mini-split air conditioning units up to 25,000 BTU/hr
- Self-priming pump
- **Includes:** safety switch, suction tubing, vent tubing and drain tubing, and tubing adapter

Locke#

L0935 EC400 230v Pump

L0944 EC400 115v Pump

Little GIANT Pump Company
AUTOMATIC CONDENSATE REMOVAL PUMP



Low profile compact size for applications with limited space. The reservoir has a 3/10 gallon capacity. Vertical-type pump with stainless steel motor shaft, rust proof, high impact ABS volute, tank and motor cover. Discharge is a 3/8" O.D. barbed tubing adapter/check valve. Pump features a safety switch that can be connected to shut down the air conditioner condenser or wired to an alarm to warn of possible tank overflow. Pump is rated for high-efficiency gas furnace applications that produce an acidic condensate. Thermally protected motor is UL and CSA listed.

- 1/30 HP motor
- 6' power cord

Locke#

L0991 VCC20 Condensate Pump

Little GIANT Pump Company
FLOAT VALVE FOR EVAPORATOR COOLER



Locke#

L4974 FV-2 Float Valve for Evaporative Cooler

Little GIANT Pump Company
EVAPORATOR COOLER PUMP

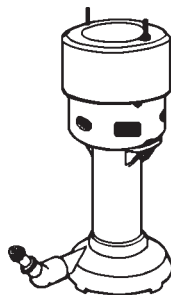

Locke#

L4970 CP-6500 1/70HP,115V Evaporative cooler pump

Little GIANT Pump Company
AUTOMATIC CONDENSATE UNITS FOR CONDENSATE & WASTE WATER APPLICATIONS

Medium Tank Model

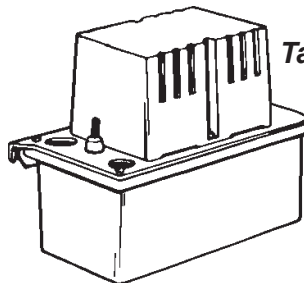

Vertical type pumping unit, with high impact polystyrene tank, ABS motor, & tank covers, volute & impeller. Thermally protected. Stainless steel shaft. Snap action switch, 6' cord with 115 volt plug. Pump engages in 2.5" of water, disengages in 1.125" of water. Includes check valve with 3/8" OD discharge.

Locke#

L0928 VCM-15ULS 7" H x 9 1/4" L x 4 1/2" W Automatic Condensate Vertical Unit

Little GIANT Pump Company
AUTOMATIC CONDENSATE REMOVAL PUMP



- Includes 20' of 3/8" ID tubing
- Safety switch
- UL / CSA listed
- Stainless steel shaft
- 3 inlet drain holes

- 1/30 HP high performance motor
- ABS tank, motor cover, and volute
- 1/2 gallon tank capacity
- Removable 3/8" barbed check valve
- Thermal overload protection

Locke#

L0945 554435 Condensate Pump

Little GIANT Pump Company
AUTOMATIC "IN-PAN" CONDENSATE & WASTEWATER PUMP



Float-operated, 1/150 HP pump. Used to remove condensation from duct lines, & other areas. Pumps up to

205 GPH, designed for in-pan mounting. Float engages pump in 1.06" of water & shuts off at 1/2" of water. 1/4" IP thread discharge.

Locke#

L0927 Condensate Pump



CONDENSATE PUMP 22' LIFT • WITH TUBING



Vertical type pumping unit, with high impact ABS tank, ABS motor and tank covers, volute and impeller.

Thermally protected motor and stainless steel shaft. 6' cord with 3-prong molded plug. Pump engages in 2.5" of water, disengages in 1.125" of water. Includes safety switch and a removable check valve with 3/8" discharge. Four inlets provide greater installation versatility. UL approved.

Locke#

L5231 CP-22T 115V Condensate Pump



WET SWITCH FLOOD DETECTOR



A solid state control designed to help prevent flooding, damage to carpets, walls, furniture, ceilings, etc. Turns system off when detecting moisture due to condensate or drain leaks. One or two drops will cause Wet Switch to turn off a unit, alerting a serviceman to a moisture problem. A lit LED indicates the Wet Switch is activated and has turned the unit off. Reset simply by drying the absorbent pad with a paper towel and momentarily interrupting the power. Connects to 24 VAC. More than one unit may be connected to a system. 2 amp contact rating. Simple 3 wire installation.

Locke#

T0177 WS-1 Wet Switch Flood Detector

MA-LINE FLOOD ALERT



PREVENTS OVERFILLING WATER
Water reaches sensor level and alarm is triggered to remind the most forgetful bather that their bath is full. Save precious fresh water. Also for use on the floor, in a bathroom or a cellar, swimming pools, sinks, washing machines, etc. LED ALERT EXTRA LOUD WARNING

Locke#

T0657 MA-1665A Flood Alert



A/C CONDENSATE FLOAT SWITCH

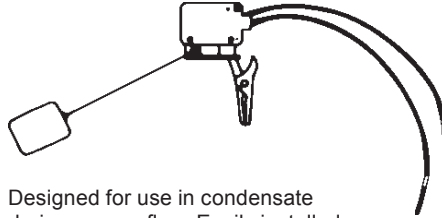

Designed for use in condensate drain pan overflow. Easily installed on the side of the auxiliary drain pan. Single pole, double throw normally OPEN or normally CLOSED.

Locke#

L2417 6-JMP Condensate Float Switch



MINI FLOWATCH®2 CONDENSATE PUMPS



- 4 GPH
- 24' Max. Lift
- Vertical Suction
- Lowest Noise Level <21dB
- Thermally protected
- Alarm level to prevent overflow
- Waterproof connections prevent water ingress
- Piston pump provides long life
- Optional Mounting Kit (GC1KFX2010)
- 2 year warranty

Locke#

L5117 DE05LUA520 Mini Flowatch®2 Condensate Pump (120V)

L5118 DE05LUA720 Mini Flowatch®2 Condensate Pump (240V)



AQUAGUARD™ AQUAGUARD AG-1 FLOAT SWITCH.

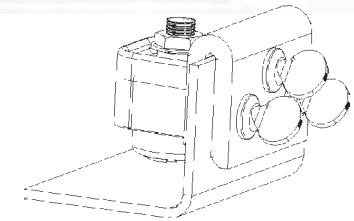
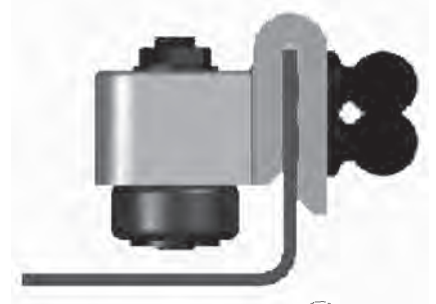

The A/C AquaGuard Model AG-1 is a reliable overflow shutoff switch for auxiliary drain pans and is designed to provide the homeowner with an early warning alert to potential danger due to the Condensate Drip Pan overflowing.

Benefits of the A/C AquaGuard:

Unlike other switches on the market today, the AquaGuard does not require any drilling or screwing of the switch to the drip pan.

The AquaGuard AG-1 is incredibly easy to install.

It can be mounted to the drain pan in 10 seconds or less and is the only switch in this category that does not require a hole in the pan.

The AquaGuard AG-1 is the only float switch with a protective cover to keep out insulation and debris that could prevent the float from rising.

The AquaGuard AG-1 uses a pest-resistant plastic float.

At the heart of the AG-1 is an American-made reed switch just like the ones installed to deploy air bags in millions of American autos.

The AquaGuard AG-1 is easy to install.

The AquaGuard AG-1 has a THREE YEAR limited warranty.

The AquaGuard AG-1 has superior buoyancy and sensitivity.

The AquaGuard AG-1 comes with a 7-foot lead

The AquaGuard AG-1 is rustproof and waterproof

Locke#

L3307 AG-1 Float Switch

HVAC

SAFE-T-SWITCH®

LOW VOLTAGE A/C CONDENSATE OVERFLOW SHUT-OFF SWITCH



Model SS1

Detects downstream clogs in A/C condensate drains and shuts off the system to prevent flooding. Designed for in line installation vertically or horizontally at any slope in primary condensate drains. Features optional plugged installation on auxiliary drain pan outlets. Small footprint fits well in tight spots. Sealed, waterproof reed/ magnet float switch technology ensures long term, reliable performance with no exposed electrical contacts to corrode, short out or fall off. Ships pre-wired with 4-Foot, 18-gauge lead wires. One electrical connection required during installation, **usually inside the air handler electrical compartment.**

Locke#

L2506	SS1	In Line Condensate Shut-Off Switch - Includes (2) 3/4" Bushings and a Plug
--------------	-----	--

Model SS2



Detects downstream clogs in A/C condensate drains and shuts off the system to prevent flooding. Designed for installation on auxiliary drain pan outlets or can be installed on alternate primary outlets when available on some equipment models. Requires no plug; small footprint fits well in tight spots. Sealed, waterproof reed/ magnet float switch technology ensures long term, reliable performance with no exposed electrical contacts to corrode, short out or fall off. Ships pre-wired with 4-Foot, 18-gauge lead wires. One electrical connection required during installation, **usually inside the air handler electrical compartment.**

Locke#

L2507	SS2	Residential Shut-Off Switch for auxiliary drain pan outlets
--------------	-----	---



A/C CONDENSATE PANS



Features:

- New rolled edges for durability
- New ribbed bottoms for rigidity
- New reinforced corners for strength
- 3/4" PVC fittings attached to each pan
- No seams - no rust - no leakage
- Five pans per master carton
- Complies with Southern Building Code No.94167

L = Drain Line Outlets in Long Side
S = Drain Line Outlets in Short Side
Southern Building Code #94167

Locke#	Vendor#	Bottom Dimension	Overall Dimension	Depth
L2405	6-18388	18"x38"	20"x40"	2"
L2406	6-18468	18"x46"	20"x48"	2"
L2411	6-2739L	27"x39"	29"x41"	2"
L2407	6-3030L	30"x30"	32"x32"	2"
L2408	6-3060L	30"x60"	32"x62"	2"
L2409	6-3636L	36"x36"	38"x38"	2"
L2410	6-3660L	36"x60"	38"x62"	2"



CLEARVUE CONDENSATE PUMP 22' LIFT

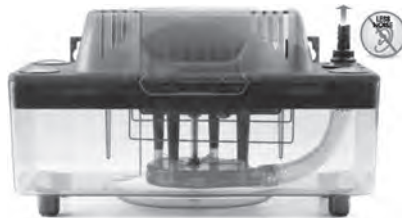

Floatless Sensor™ Technology
Push Button Drain
Clear Tank
Check Valve
Molded Silicone Rubber Feet
Stainless Steel Hang Tabs
LED Indicator Lights
Self-Cleaning
High Level Alarm Connection

Locke#

L5230	IQP-120 115V Condensate Pump
--------------	------------------------------



AquaGuard™ THE GOLIATH SECONDARY DRAIN PAN



The Goliath, true to its name, is the strongest, most rugged HVAC secondary pan on the market. All of the benefits of the DexElar material combine with engineered structural strength to produce a nearly indestructible drain pan. All Goliath pans are ASTM E-84-05 rated. Designed for horizontal installation and comes with 16 VI-4200 vibration isolators. Order the AG-4200 float switch system.

NOTE: With each L5310 or L5311 drain pan ordered, you must also order the L5314 drain pan switch

Locke#

L5310	AG-G28x56	The Goliath 28x56 Secondary Drain Pan
L5311	AG-G30x60	The Goliath 30x60 Secondary Drain Pan
L5314	AG-4200	Goliath Drain Pan Switch



CLEARVUE CONDENSATE PUMP 22' LIFT



Floatless Sensor™ Technology
Push Button Drain
Clear Tank
Check Valve
Molded Silicone Rubber Feet
Stainless Steel Hang Tabs
LED Indicator Lights
Self-Cleaning
High Level Alarm Connection

Locke#

L5230	IQP-120 115V Condensate Pump
--------------	------------------------------

intec Wasp
INSULATION MACHINE
WITH ACCESSORIES



Its small size and pleasing aesthetics disguise this all-fiber workhorse's aggressive output. With cellulose production rates over 1700 lbs per hour and fiberglass production rates over 475 lbs per hour, the Wasp insulates an average attic in less than one hour.

Portability is made easy with built in handles and wheels. Dense Pack of both cellulose and fiberglass is made possible thru its Department Of Energy approved outlet pressure of 3.5psi, slide gate, and variable speed control. With applications varying from attic installs, dense pack, spray-in, and spray-on, both DIY'ers and contractors will obtain high payback when using this highly reliable insulation blowing machine.

Locke#

L3485 0500-0700-00 Wasp Insulation Machine with Accessories

Check out our website
lockesupply.com
For directions to our
stores, credit services,
catalog PDFs and more.

intec Wasp
DENSE PACK HOSE KIT
SINGLE REDUCER



Locke#

L3486 K26200 Dense Wall Pack used with the WASP L3485

intec Wasp
HOSE SWIVEL



Simplify spray applications - reduce hose twist & operator fatigue by installing an Intec swivel 15' to 20' from hose discharge or intake.

Locke#

L3487 J52053 3" Hose Swivel

L3488 J52046 2" Hose Swivel

intec Wasp
CLEAR HOSE



Locke#

L3489 22051 3" MARK II Hose x 50'

L3490 22049 2" MARK II Hose x 50'

intec Wasp
HOSE CONNECTOR



Locke#

L3491 22051-01 3" Connector

L3492 22049-07 2" Connector

intec Wasp
REPLACEMENT
AIRLOCK SEAL



Locke#

L3493 22013 Wasp Airlock Seal

HVAC

**WE DO MORE
THAN JUST
MEET OUR
COMPETITION,
WE BEAT
THEM.
COMPARE
OUR PRICES
AND SAVE!!**



**REFLECTIVE-DOUBLE
BUBBLE-REFLECTIVE
INSULATION**

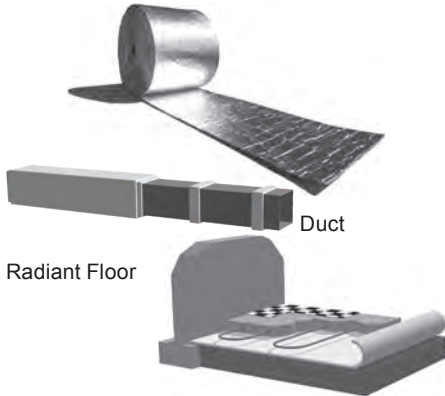

Thermo Reflect Duct Insulation is a double layer of poly-bubbles bonded to and sandwiched between two sheets of a unique Radiant Barrier metallicized reflective. Its unique construction is specially designed to help reduce condensation and radiant heat gain or loss in HVAC ducts... and no fire or flammability worries ... it passes NFPA Full Room Burn Test.

USES:

- Under Floor Radiant Heating
- Water Pipe & Air Duct
- Crawl Space
- Wall & Ceiling Vapor Barrier
- Water Tank Heater
- Garage Doors
- And more

ADVANTAGES:

- Highly Reflective
- Safe. Clean. Non Carcinogenic
- Lightweight, Compact & Tough
- Water Resistant
- Vapor & Wind Barrier
- Fire Retardant
- Easy Installation
- 4'x125'x3/8"

R4.3 without air space, R5.5 with foil bubble spacer, R6 with foam Spacer.

Locke#

L0411 48"x125' Reflective Insulation

L0416 T1DK00001 48" Long Thermo Spacer Kit - 50pcs

L0417 T1DK00002 12" Long Thermo Spacer Kit - 40pcs



**ATTIC TENT ATTIC DOOR
INSULATOR**

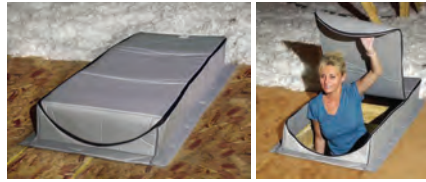

The Attic Tent has an insulating value of R-3.2. It is a specially engineered, patented insulator designed to create an air transfer barrier between your attic and living areas. It is a practical and economical solution to a problem that has existed since homes were first built with overhead attic entries.

That problem is wasted energy through and around the attic door and stairs. It insulates folding attic stairs, knee wall doors, and attic scuttle holes.

The AT-4 is 25"W x 54" x 13"H and fits attic ladders with a 25" x 54" opening and 1x5 or 1x6 side rail.

Installs in 4 Easy Steps:

- Measure how high the attic stairs are above the rough frame (2x6). This will determine the height of Attic Tent needed. Attic ladder side rails made with a (1x5) or (1x6) need a 13inch height Attic Tent.
- Place Attic Tent with the zipper heads at the hinge end of the attic stair box.
- Staple the mounting flange to the rough frame, on all four sides about every 2 -3 inches.
- Seal between mounting flange and rough frame with a bead of caulk.

Locke#

L3497 AT-4 Attic Tent



**PLASTIC INSULATION
PLUGS**



Locke#

L3496 PL-2 2" Insulation Plugs



POLY RAFTER VENTS



Locke#

L3494 PB2248 22" x 48" Rafter Vents

CertainTeed
**VINYL FACED DUCT
WRAP INSULATION**

Type #75

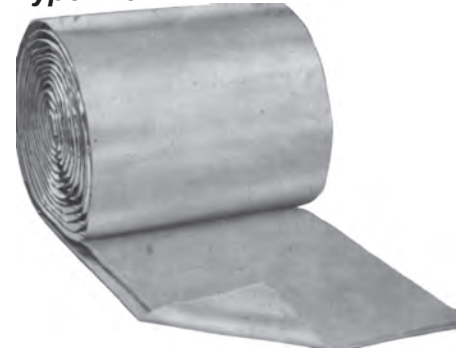

For concealed and exposed hot, cold or dual-temperature air handling systems.

Locke#

L0474 1 1/2" x 48" x 100' Vinyl Faced Duct Wrap Insulation

L0476 2" x 48" x 75' White Vinyl Faced Duct Wrap Insulation

CertainTeed
**FRK FOIL FACE DUCT
WRAP INSULATION**

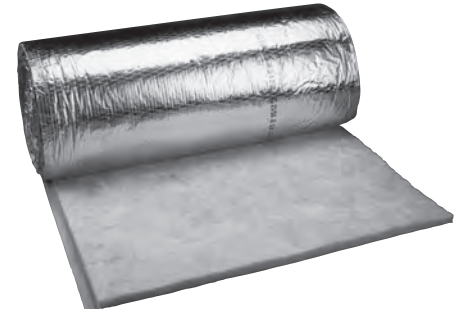

For concealed and exposed hot, cold, or dual temperature air handling systems.

Locke#

L0472 #75 1 1/2"x48"x100' FRK Foil Face Duct Wrap Insulation

L0475 #75 2"x48"x75' FRK Foil Face Duct Wrap Insulation

L0479 #75 3"x48"x50' FRK Foil Face Duct Wrap Insulation

Check out our website
lockesupply.com
For directions to our
stores, credit services,
catalog PDFs and more.

HVAC

CertainTeed FIBERGLASS DUCT BOARD

Duct Board Cutting Tools sold in "T" Section.

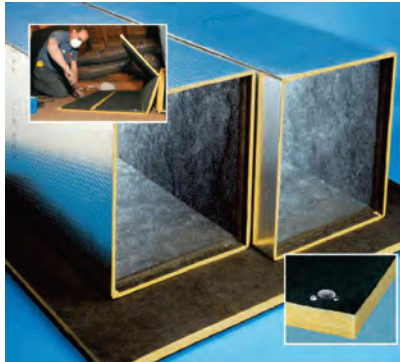

Rigid fiberglass board used in constructing rectangular, pre-insulated duct work. 6 sheets per box.

Locke#

L0422	#475	1" x 48" x 96"	Fiberglass duct board
L0470	#475	1" x 48" x 120"	Fiberglass duct board
L0424	#475	1½" x 48" x 120"	Fiberglass duct board

CertainTeed DUCT LINER



A thermal & acoustical glass fiber insulation. Absorbs unwanted sounds. Designed for use as an acoustical &/or thermal insulation for heating & cooling ducts.

Locke#

L0509	#200	½" x 35½" x 100'	Duct Liner
L0471	#200	½" x 47½" x 100'	Duct Liner
L0421	#200	½" x 59½" x 100'	Duct Liner
L0420	#150	1" x 35½" x 100'	Duct Liner
L0423	#150	2" x 47½" x 50'	Duct Liner
L0473	#150	1" x 47½" x 100'	Duct Liner

Shurtape® 11.5mil CONTRACTOR GRADE CLOTH DUCT TAPE



Marked to meet code requirements.

Locke#

L0493	PC 621	Cloth - Gray with Print	2" x 60' yds; 24/case; UL723
--------------	--------	-------------------------	------------------------------

Shurtape® CONTRACTOR GRADE METALIZED CLOTH DUCT TAPE WITH PRINT



Shurflex Contractor grade metalized cloth duct tape used for air-tight and moisture-free sealing, seaming and joining aluminum-backed flex ducts and sealing metal ducts.

Locke#

L0447	SF 683	Metalized Silver/Black print	2"x60yds; 24/case
--------------	--------	------------------------------	-------------------

Shurtape® 3 mil PRINTED OPP ACRYLIC ADHESIVE



Designed for use on Class 1 Flex Duct for connecting, joining, sealing and patching flexible air ductwork. UL 181B-FX listed. Colors: metalized silver with red print and black with white print.

Locke#

L0445	DC 181	3" Metalized Silver	3" x 120 yds; 16/case
L0446	DC 181	2" Metalized Silver	2" x 120 yds; 24/case

Shurtape® 9mil GENERAL PURPOSE CLOTH POLYCOATED DUCT TAPE



Used for use in packaging, bundling, sealing, seaming, holding, waterproofing, plumbing, carpet, color coding, splicing, and other home and general repairs.

Locke#

L0546	PC 600	General purpose grade Gray	2" x 60 yds; 32/case
--------------	--------	----------------------------	----------------------

Shurtape® 14mil SPECIALTY GRADE CLOTH DUCT TAPE



HVAC Class 1 Flex Duct applications, installing air ducts and air connectors, and making connections and splices trouble-free and professionally-done. For use when the tensile strength and adhesion to stainless steel and polyethylene must meet or exceed the strict requirements of UL, flex duct manufacturers, and city and state building codes. UL 181 B-FX listed.

Locke#

L0449	PC857	Silver cloth with black print	2" x 60yds; 24/case
--------------	-------	-------------------------------	---------------------

Shurtape® INDUSTRIAL GRADE VINYL-COATED GAFFER'S TAPE



To seal Armoflex joints, etc. Waterproof and weatherproof.

Locke#

L0469	PC 628	Cloth exterior grade vinyl coat/black	2"x60yds
--------------	--------	---------------------------------------	----------

HVAC

Shurtape® 10mil LIGHT INDUSTRIAL GRADE CLOTH DUCT TAPE



Used to seal cartons, bind books, repair seats, bundle wires, color code, splice, repair. Use as a condensation barrier in appliance assemblies. Tested in accordance with UL 723.

Locke#

L0468 PC 618 General Cloth, Nonprint White 3" x 60 yds; 16/ case

Shurtape® 2mil ALUMINUM FOIL TAPE



BOCA Code Approved. Joins and seals fiberglass ductboard and Class 1 Flex Duct. Air-tight seal. UL-181A-P/B-FX listed.

Locke#

L0494 AF 100 Aluminum foil with red print 2½" x 60yds; 20/case

Shurtape® 2mil DEAD-SOFT ALUMINUM FOIL

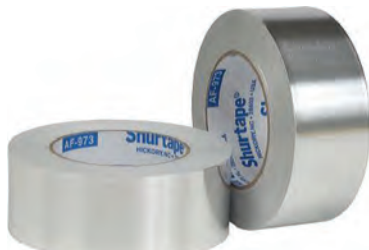

2.0 mil foil, UL 723 listed, cold temperature acrylic adhesive, provides an air tight seal in vast temperature ranges and used for joining and sealing aluminum backed or fibrous insulation and metal duct.

Locke#

L0492 AF 975 2" Aluminum Foil, non-print 2" x 50 yds; 24/case

L0480 AF 975 3" Aluminum Foil, non-print 3" x 50 yds; 16/case

Shurtape® FOIL-SCRIM-KRAFT BACKING



FSK foil, UL 723 listed cold temperature acrylic adhesive, provides an air tight seal in vast temperature ranges and used for sealing seams in scrim reinforced duct insulation. Used where maximum strength tape is needed.

Locke#

L0499 AF 984 2" Aluminum Foil/ scrim/kraft backing non-print 2" x 50 yds; 24/case

L0467 AF 984 3" Aluminum Foil/ scrim/kraft backing non-print 3" x 50 yds; 16/case

HARDCAST CARBIDE INDOOR/OUTDOOR MASTIC ON A ROLL PAINTABLE FOIL



Shurflex indoor/outdoor mastic on a roll used for air-tight and moisture-free sealing of rigid and flexible air duct systems. UL 723 listed.

Locke#

L0448 AFG1402 Foil with mastic back/ Blue print 2" x 100'; 24/case

Malco STRAP GUN

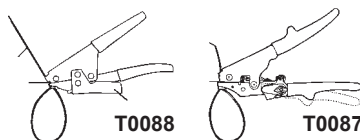

Locke#

T0088 TY4G 6" Manual Cut-off Gripped Tensioning Tool

T0087 TY6 8½" Auto Cut-off Gripped Tensioning Tool

DIVERSITECH "The Pick of the Crew"

DUCT STRAP PLASTIC ROLL

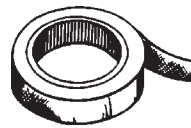

Webbed duct strap possessing high tensile and abrasion resistant. Chemical resistant. Use for flex duct - easy to cut and staple to joists.

Locke#

M0078 710-101 1¼" x 100 yards-Silver 24 Rolls

M0081 710-100 1¼" x 100 yards-Black 24 Rolls

DUCT STRAP WOVEN POLYPROPYLENE



Webbed duct strap processing high tensile and abrasion resistance. Chemical resistant. Use for flex duct. Easy to cut and staple to joists.

Locke#

M0069 710-103 3" x 100 Yards Silver

METALLIC DUCT STRAP ROLL

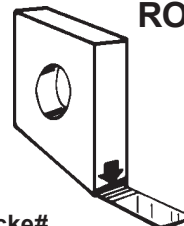

Locke#

M0079 6-CKDS1-12-H 26 Gauge, 1½" x 100' Roll

M0080 6-CKDS1-12-LT 30 Gauge, 1½" x 100' Roll

NYLON DUCT STRAPS

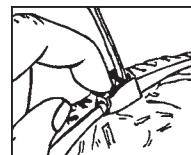

Tensile strength of 175 lb. Straps are self-locking ¾". Adjustable ¼" to 10" nylon duct straps.

Locke#

L0526 36" Fits to 10" Flexible Duct Clamps

L0527 36" Fits to 10" Flexible Duct Clamps, **Black**

L0525 48" Fits to 14" Flexible Duct Clamps

Glasfloss®

FIBERGLASS AIR FILTERS

Fibers coated with dust catching adhesive.
Faced with grilles and bound on all edges with a cardboard frame covered with printed tape.

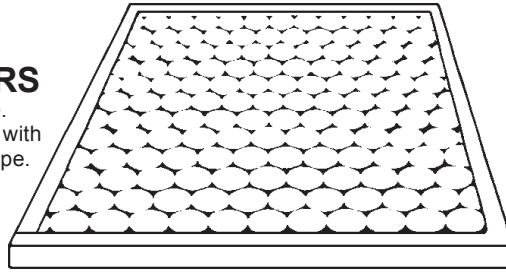

Locke#	Size	
L3233	8x20x1"	Fiberglass Filter
L3231	8x24x1"	Fiberglass Filter
L3223	8x30x1"	Fiberglass Filter
L3211	10x10x1"	Fiberglass Filter
L0450	10x20x1"	Fiberglass Filter
L3200	10x24x1"	Fiberglass Filter
L3213	10x25x1"	Fiberglass Filter
L3201	10x30x1"	Fiberglass Filter
L3250	10x36x1"	Fiberglass Filter
L3202	12x12x1"	Fiberglass Filter
L3224	12x16x1"	Fiberglass Filter
L3225	12x18x1"	Fiberglass Filter
L0519	12x20x1"	Fiberglass Filter
L3196	12x20x2"	Fiberglass Filter
L0460	12x24x1"	Fiberglass Filter
L0809	12x24x2"	Fiberglass Filter
L0454	12x25x1"	Fiberglass Filter
L3203	12x30x1"	Fiberglass Filter
L3226	12x36x1"	Fiberglass Filter
L0504	14x14x1"	Fiberglass Filter
L3238	14x16x1"	Fiberglass Filter
L3230	14x18x1"	Fiberglass Filter
L0451	14x20x1"	Fiberglass Filter
L0810	14x20x2"	Fiberglass Filter
L0461	14x24x1"	Fiberglass Filter
L0455	14x25x1"	Fiberglass Filter
L0811	14x25x2"	Fiberglass Filter
L0459	14x30x1"	Fiberglass Filter
L3239	14x36x1"	Fiberglass Filter
L3204	15x20x1"	Fiberglass Filter
L3191	15x20x2"	Fiberglass Filter
L3214	15x24x1"	Fiberglass Filter
L3215	15x25x1"	Fiberglass Filter
L3222	15x30x1"	Fiberglass Filter
L3205	16x16x1"	Fiberglass Filter
L3197	16x16x2"	Fiberglass Filter
L3227	16x18x1"	Fiberglass Filter
L0452	16x20x1"	Fiberglass Filter
L0812	16x20x2"	Fiberglass Filter
L3206	16x24x1"	Fiberglass Filter
L0819	16x24x2"	Fiberglass Filter
L0456	16x25x1"	Fiberglass Filter
L0813	16x25x2"	Fiberglass Filter
L3210	16x30x1"	Fiberglass Filter

Locke#	Size	
L3242	16x36x1"	Fiberglass Filter
L3217	18x18x1"	Fiberglass Filter
L3194	18x18x2"	Fiberglass Filter
L3221	18x20x1"	Fiberglass Filter
L3195	18x20x2"	Fiberglass Filter
L3207	18x24x1"	Fiberglass Filter
L3192	18x24x2"	Fiberglass Filter
L0457	18x25x1"	Fiberglass Filter
L3216	18x30x1"	Fiberglass Filter
L3244	19x27x1"	Fiberglass Filter
L0453	20x20x1"	Fiberglass Filter
L0814	20x20x2"	Fiberglass Filter
L3219	20x22 $\frac{1}{4}$ x1"	Fiberglass Filter
L3208	20x24x1"	Fiberglass Filter
L0815	20x24x2"	Fiberglass Filter
L0458	20x25x1"	Fiberglass Filter
L0816	20x25x2"	Fiberglass Filter
L0462	20x30x1"	Fiberglass Filter
L3193	20x30x2"	Fiberglass Filter
L3228	20x36x1"	Fiberglass Filter
L3212	22x22x1"	Fiberglass Filter
L3245	22x24x1"	Fiberglass Filter
L0465	24x24x1"	Fiberglass Filter
L0817	24x24x2"	Fiberglass Filter
L0431	24x25x1"	Fiberglass Filter
L3220	24x28x1"	Fiberglass Filter
L3209	24x30x1"	Fiberglass Filter
L3229	24x36x1"	Fiberglass Filter
L0518	25x25x1"	Fiberglass Filter
L0818	25x25x2"	Fiberglass Filter
L3218	30x30x1"	Fiberglass Filter

Glasfloss®

U-TRIM FOAM FILTERS

Locke#

L3308 15" x 24" x 1/4" Foam Pad with U-Trim

L3309 15" x 24" x 1/4" Foam Pad with Grid

Glasfloss®

CUT-TO-FIT HOGGHAIR WASHABLE AIR FILTER

Easy - just cut and install.
No messy oil or adhesive... washable.

Locke# UL class 2.

L3300 20" x 25" x 1" Hogghair Washable Filter

L3301 20" x 30" x 1" Hogghair Washable Filter

Glasfloss®

HOGGHAIR FURNACE AIR FILTER SERVICE ROLLS

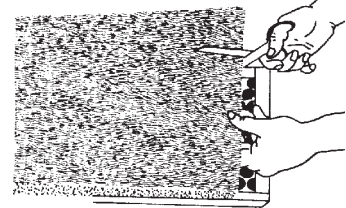

A complete filter, just cut & install. It is stiff, works without a frame. An inexpensive, convenient alternative to "special" size filters. Filters without messy oils or adhesives. Superior depth loading, very high dust holding capacity. Can be washed & reused over & over again.

Locke#

L0495 1" x 25" x 30' Hogghair Furnace Air Filter

L0498 1" x 20" x 30' Hogghair Furnace Air Filter

Glasfloss®

HONEYWELL REPLACEMENT FILTERS

Locke#

L3358 HWP20204 20x20x4 Z-Line 400 HW Replacement Filter

L3359 HWP20254 20x25x4 Z-Line 400 HW Replacement Filter

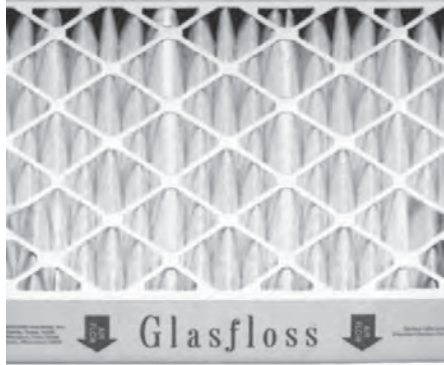

Glasfloss®

PLEATED RETURN AIR FILTER

ZLP series filters are extended surface area filters. The filter is made of a nonwoven cotton fabric, which has an average arrestance of 93%. It is enclosed in a rigid, heavy-duty, high wet strength beverage board. The inside of the enclosed frame is bonded to the filter pack, thus eliminating the possibility of air leaks. The expanded metal support grid creates a radial pleat design with an open area of 96%. This allows for the total use of the filter material. This filter can be used in upgrading old systems for greater dust holding capacity, extends replacement intervals & lengthens the service life of any other secondary filter considerably.

Locke#	Size	
L3360	8x14x1"	Pleated Filter
L3361	8x20x1"	Pleated Filter
L3362	8x24x1"	Pleated Filter
L3364	8x30x1"	Pleated Filter
L3365	10x10x1"	Pleated Filter
L3366	10x14x1"	Pleated Filter
L3259	10x20x1"	Pleated Filter
L3275	10x24x1"	Pleated Filter
L3367	10x25x1"	Pleated Filter
L3368	10x30x1"	Pleated Filter
L3369	12x12x1"	Pleated Filter
L3370	12x14x1"	Pleated Filter
L3371	12x16x1"	Pleated Filter
L3372	12x18x1"	Pleated Filter
L3260	12x20x1"	Pleated Filter
L3261	12x24x1"	Pleated Filter
L3373	12x25x1"	Pleated Filter
L3293	12x30x1"	Pleated Filter
L3374	12x36x1"	Pleated Filter
L3274	14x14x1"	Pleated Filter
L3375	14x16x1"	Pleated Filter
L3376	14x18x1"	Pleated Filter
L3262	14x20x1"	Pleated Filter
L3271	14x24x1"	Pleated Filter
L3263	14x25x1"	Pleated Filter
L3272	14x30x1"	Pleated Filter
L3377	14x36x1"	Pleated Filter
L3264	15x20x1"	Pleated Filter
L3258	16x16x1"	Pleated Filter
L3317	16x18x1"	Pleated Filter
L3265	16x20x1"	Pleated Filter
L3318	16x22x1"	Pleated Filter
L3257	16x24x1"	Pleated Filter
L3266	16x25x1"	Pleated Filter
L3294	16x30x1"	Pleated Filter
L3320	16x36x1"	Pleated Filter
L3321	18x18x1"	Pleated Filter
L3322	18x20x1"	Pleated Filter
L3267	18x24x1"	Pleated Filter
L3277	18x25x1"	Pleated Filter
L3324	18x30x1"	Pleated Filter
L3268	20x20x1"	Pleated Filter

Locke#	Size	
L3326	20x22¼x1"	Pleated Filter
L3276	20x24x1"	Pleated Filter
L3269	20x25x1"	Pleated Filter
L3292	20x30x1"	Pleated Filter
L3327	20x36x1"	Pleated Filter
L3328	22x22x1"	Pleated Filter
L3329	22x24x1"	Pleated Filter
L3330	22x25x1"	Pleated Filter
L3270	24x24x1"	Pleated Filter
L3336	24x25x1"	Pleated Filter
L3331	24x28x1"	Pleated Filter
L3332	24x30x1"	Pleated Filter
L3333	24x36x1"	Pleated Filter
L3273	25x25x1"	Pleated Filter
L3335	30x30x1"	Pleated Filter
L3295	12x20x2"	Pleated Filter
L3280	12x24x2"	Pleated Filter
L3281	14x20x2"	Pleated Filter
L3282	14x25x2"	Pleated Filter
L3283	15x20x2"	Pleated Filter
L3302	16x16x2"	Pleated Filter
L3284	16x20x2"	Pleated Filter
L3291	16x24x2"	Pleated Filter
L3285	16x25x2"	Pleated Filter
L3296	18x18x2"	Pleated Filter
L3297	18x20x2"	Pleated Filter
L3286	18x24x2"	Pleated Filter
L3298	18x25x2"	Pleated Filter
L3287	20x20x2"	Pleated Filter
L3288	20x24x2"	Pleated Filter
L3289	20x25x2"	Pleated Filter
L3299	20x30x2"	Pleated Filter
L3290	24x24x2"	Pleated Filter
L3278	25x25x2"	Pleated Filter
L3350	12x24x4"	Pleated Filter
L3351	16x20x4"	Pleated Filter
L3352	16x25x4"	Pleated Filter
L3354	20x20x4"	Pleated Filter
L3355	20x24x4"	Pleated Filter
L3356	20x25x4"	Pleated Filter
L3357	24x24x4"	Pleated Filter

HVAC

Glasfloss®

SERVICE ROLLS

"Cut Your Own Size"

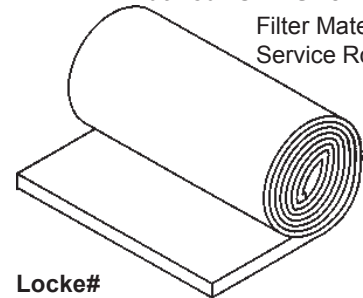

Filter Material
Service Roll Media

Locke#	
L0487	24"x20"x1" Polyester service rolls
L3306	30"x20"x1" Polyester service rolls
L3304	24"x20"x1" Fiberglass Service Rolls
L3305	30"x20"x1" Fiberglass Service Rolls

THE ULTRA ELECTROSTATIC AIR FILTER

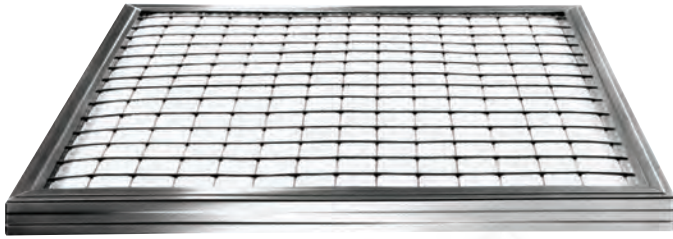

NEW & IMPROVED DESIGN!!
LIFETIME WARRANTY
ASHRAE TESTED mer V 7
LOW 0.12 INITIAL RESISTANCE!!

NEW FILTER MEDIA ALLOWS COMPLETE CLEANING:

- Arrests* 88% Air Pollutants
- Recommended By Allergists
- Permanent (No Replacement)
- All Sizes Available

**PERMANENT!
EASY TO
CLEAN!**



MERV 7

ULTRA is manufactured with **MICRO-CK'R™** Family of products with a bacteria fighting additive built in. This bacteria fighting dimension of the **ULTRA** filter is a safe & effective way to inhibit growth of bacteria, fungi, & mold that your **ULTRA** filter will trap.

sPeCiAl or Der ! - non-stocked sizes can be special ordered.

Air Cleaners will drop ship directly to the branch within a week after receipt of the order.

Locke#	Inches
L1315	10" x 20" x 1"
L1290	12" x 12" x 1"
L1314	12" x 20" x 1"
L1316	12" x 24" x 1"
L1291	12" x 30" x 1"
L1313	14" x 14" x 1"

Locke#	Inches
L1317	14" x 20" x 1"
L1318	14" x 24" x 1"
L1319	14" x 25" x 1"
L1324	14" x 30" x 1"
L1298	10" x 24" x 1"

Locke#	Inches
L1320	16" x 20" x 1"
L1295	16" x 24" x 1"
L1322	16" x 25" x 1"
L1296	16" x 30" x 1"
L1297	18" x 24" x 1"
L1321	20" x 20" x 1"

Locke#	Inches
L1327	20" x 24" x 1"
L1323	20" x 25" x 1"
L1326	20" x 30" x 1"
L1325	24" x 24" x 1"
L1328	24" x 30" x 1"

BUY THE BEST • PAY ONLY ONCE • BE HAPPY FOR LIFE!!

G-WIZZ FILTER CLEANER & DEGREASER

FOR SUPERIOR ELECTROSTATIC AIR FILTER CLEANING & DEGREASING

SAFE, NONTOXIC, BIODEGRADABLE AND NONFLAMMABLE

Excellent Coil Cleaner

Use on Vent-a-hood Filters

Safe on aluminum, stainless and most metal surfaces.

Locke#

M0851 BC25832 Cleaner / Degreaser



HVAC